

MODEL AT 1500

UV DISINFECTION SYSTEM

INSTALLATION AND OPERATION MANUAL

The Model AT 1500 UV system is listed with Underwriters Laboratories (UL) under Standard 979 as a residential treatment device. In addition to the UL listing, a power disconnect switch is included with each system to de-energize the unit during service and should be mounted to the exterior of the facility being served. Electrical work must be performed in accordance with the latest edition of the National Electrical Code, as well as all applicable local codes. **CAUTION: DO NOT LOOK DIRECTLY AT THE UV LAMP OR EXPOSE SKIN DURING OPERATION. PERMANENT EYE DAMAGE AND SKIN BURNS WILL OCCUR FROM UV RADIATION EXPOSURE. UV BLOCKING SAFETY GLASSES ARE PROVIDED WITH EACH SYSTEM AND MUST BE WORN DURING INSTALLATION, SERVICE OR ANY TIME THE BULB MAY BE ILLUMINATED.**

COMPONENTS

The Model AT 1500 UV disinfection system consists of the following components:

- | | |
|---------------------------|---|
| 1) Control enclosure | 9) UV subassembly with anodized aluminum frame, quartz sleeve and Teflon sheath |
| 2) Disconnect switch | |
| 3) 4" ABS riser pipe | |
| 4) 4" ABS inlet coupling | |
| 5) Turbulence inducer | 10) Subassembly handle |
| 6) 4" ABS outlet coupling | 11) Dielectric grease (5 g) |
| 7) Disinfection chamber | 12) UV safety glasses |
| 8) UV lamp (bulb) | |

These components should be supplied by the installer:

- | | |
|------------------------|-------------------------------|
| 1) Solvent cement | 5) Isopropyl alcohol |
| 2) Hacksaw | 6) #14/2 AWG electrical cable |
| 3) Glycerin (optional) | 7) Conduit and fittings |
| 4) Clean, soft cloth | |

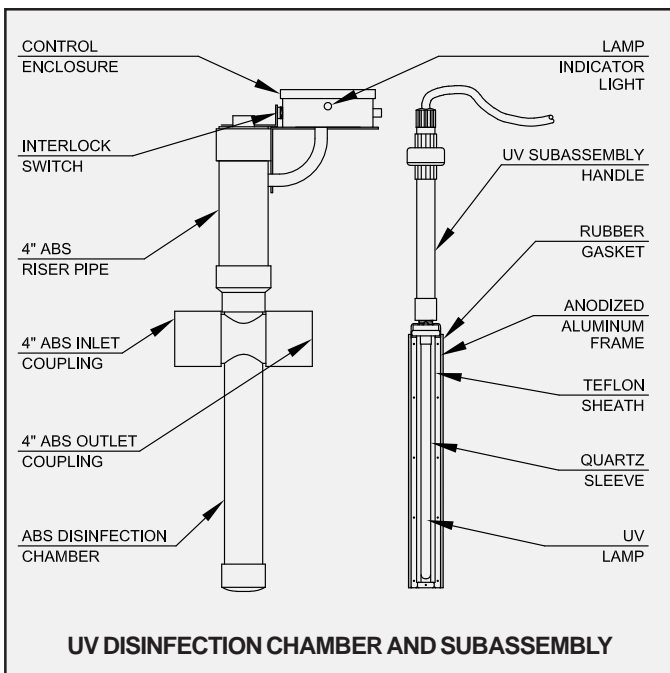

INSTALLATION INSTRUCTIONS

1. The excavation for the wastewater treatment system upstream of the UV disinfection device should include an additional 3 feet of length to allow for installation of the Model AT 1500.
2. Carefully unpack the Model AT 1500 system. Remove and properly discard all packaging materials from the system components. The UV lamp should remain in the protective shipping sleeve until it is installed.
3. Insert the turbulence inducer into the 4" inlet coupling. Solvent weld the inlet coupling to the disinfection chamber with the turbulence inducer towards the chamber. Solvent weld the 4" outlet coupling to the disinfection chamber.

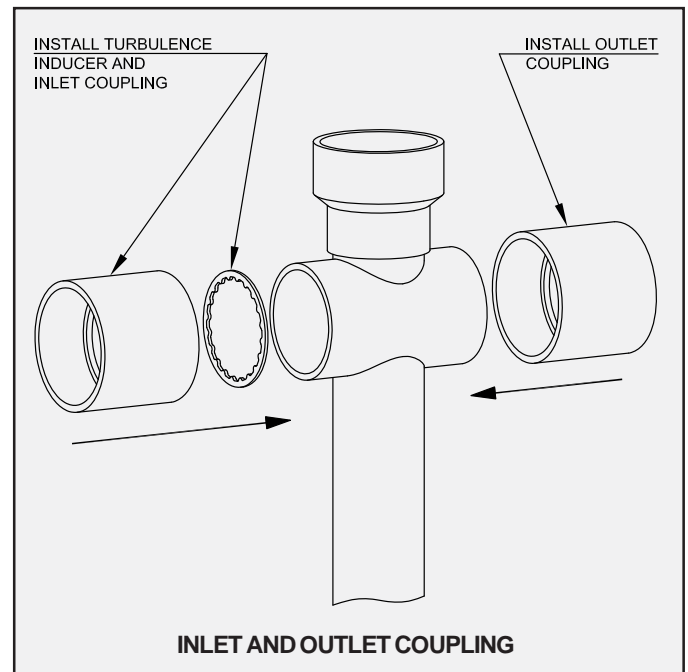

4. Solvent weld the effluent line of the upstream treatment system to the 4" inlet coupling of the Model AT 1500. Next, solvent weld the 4" outlet coupling to the final effluent line. Cover the open top of the disinfection chamber and backfill up to the bottom of the plumbing.

ULTRAVIOLET DISINFECTION (Cont.)

5. The control enclosure and mounting bracket should be completely above grade in the finished installation. The riser pipe and UV handle are purposely manufactured longer than necessary and must be trimmed. Fit the riser pipe into the top of the disinfection chamber and mark a trim line on the BOTTOM. Mark the subassembly handle on TOP to trim the same amount.

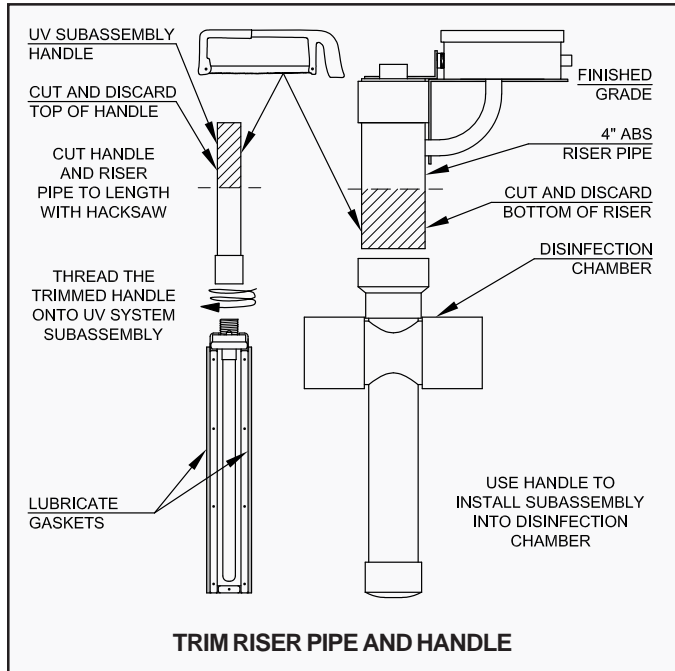

6. Use a hacksaw to cut along the trim line on both the riser pipe and handle to make them the proper length.
 7. Solvent weld the riser pipe to the disinfection chamber. Solvent weld the lower portion of the 1" union to the top of the UV subassembly handle.
 8. Disassemble the union and set aside the top portion and UV power cable. Thread the lower portion of the handle onto the UV system subassembly.

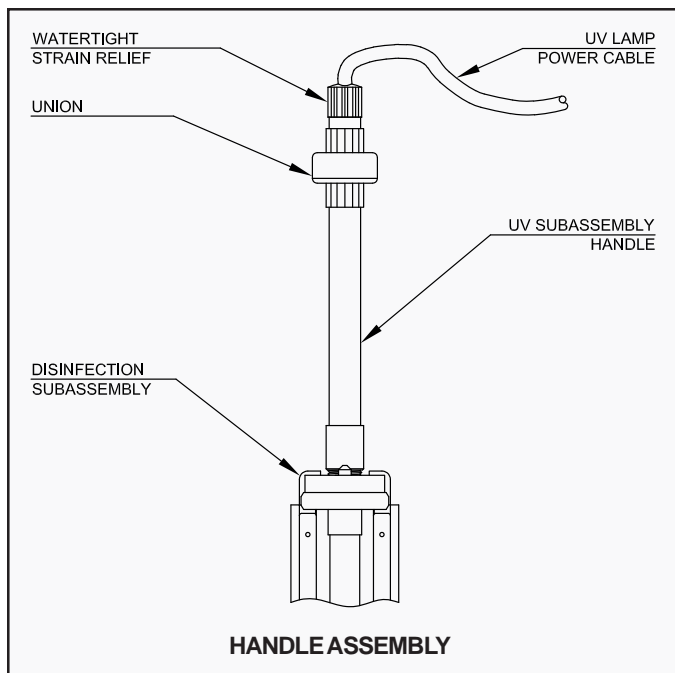

9. The Model AT 1500 is shipped with the UV lamp power cable connected to the control enclosure. If this lamp power cable has become disconnected, it must be reconnected at this time. To do so, remove the gasketed cover from the control enclosure. Connect the white lead on the UV lamp power cable to the terminal block marked "UV+". Connect the black lead on the cable to the terminal block marked "UV-".

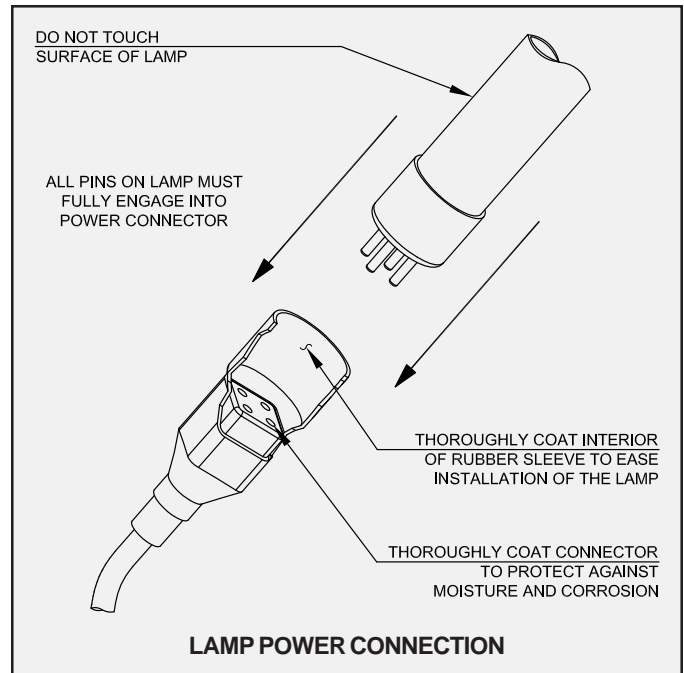

10. Use the entire tube of dielectric grease to thoroughly coat the four pin connector and interior of the black rubber sleeve. This is critical to protect against moisture, corrosion and to ease installation of the lamp into the power connector. Use a clean, soft cloth to grasp the UV lamp and insert it into the rubber sleeve. Securely attach the UV lamp to the connector. Holding the power cable, carefully insert the lamp through the handle and completely into the quartz sleeve of the UV subassembly.
 11. Assemble and tighten the union in the handle to insure a watertight connection.
 12. Use water or glycerin to lubricate the rubber gaskets located on both sides of the UV subassembly.
 13. Do not touch the Teflon sheath or allow excess glycerin to contact it. Use a clean, soft cloth moistened with isopropyl alcohol to remove any fingerprints or glycerin from the sheath.
 14. Fill the disinfection chamber with clean water.
 15. Insert the UV subassembly into the disinfection chamber. Insure the locating pins in the chamber lock into the openings on the subassembly.

MANUFACTURED BY

norweco[®]

*Engineering the future of water
and wastewater treatment*

**NORWECO, INC.
NORWALK, OHIO
U.S.A. 44857**

www.norweco.com

ULTRAVIOLET DISINFECTION (Cont.)

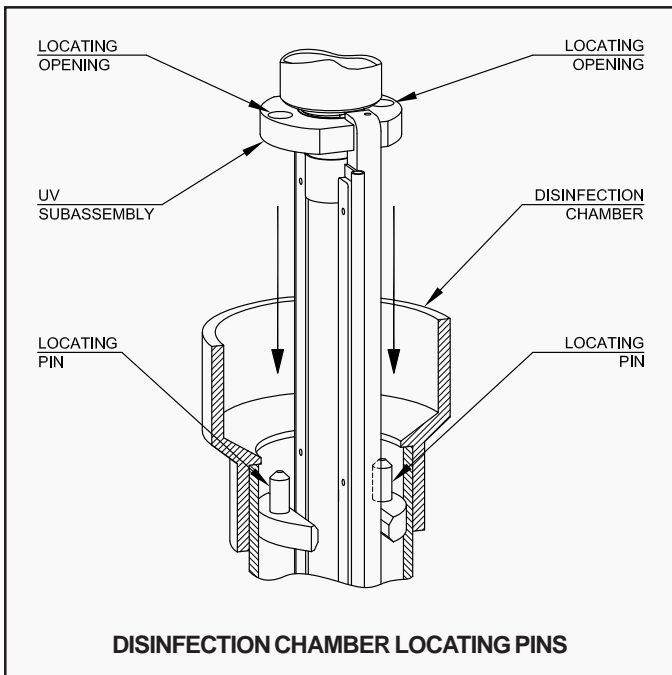

16. Tuck the excess power cable into the riser pipe.
17. Use a dedicated 115 volt AC single phase 15 amp (minimum) circuit in the main electrical panel for service to the UV disinfection system. **NOTE: Make sure the breaker is "off" before proceeding.**
18. Mount the power disconnect switch to the facility being served. Remove the black insulator from the disconnect switch enclosure.
19. Install a #14/2 AWG cable from the dedicated breaker in the main electrical panel to the disconnect switch.
20. In the disconnect switch enclosure, connect the hot (black) lead from the main electrical panel to the "Line" terminal on the left side of the enclosure. Connect the black lead to the UV system to the "Load" terminal on the left side of the enclosure. Twist both white leads

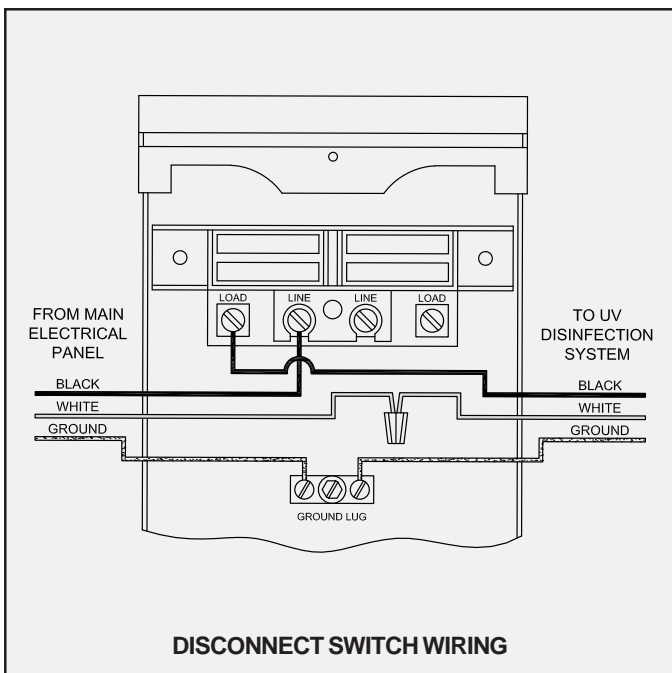

21. together and secure with a wire nut connector. Connect both ground leads to the ground lug in the enclosure.
21. Remove the control enclosure cover. Install a #14/2 AWG cable from the disconnect switch to the control enclosure. Insure the connection to the UV system is made in conduit with the conduit fittings provided. A watertight connection is critical to insure proper operation and safety. Replace black disconnect switch insulator.
22. Attach the incoming hot (black) lead to the terminal block marked "L" in the UV control enclosure. Attach the common (white) lead to the terminal block marked "N" in the enclosure. Attach the incoming ground lead to the terminal block marked "G" in the enclosure.
23. (Optional) If a remote alarm panel is required, the alarm leads should be installed in a separate conduit using the second conduit fitting provided. A watertight connection is critical to insure proper system operation and safety. Connect one alarm lead to either the normally open (N/O) terminal or the normally closed (N/C) terminal. Choose the correct terminal for the type of signal required by the remote alarm panel. Connect the other lead to the common (COM) terminal.
24. Solvent weld a plug into any unused conduit fittings to insure watertight integrity is maintained.
25. Secure the gasketed cover in place on the top of the control enclosure, using the four screws provided.
26. Install the 4" threaded ABS cap onto the riser pipe.

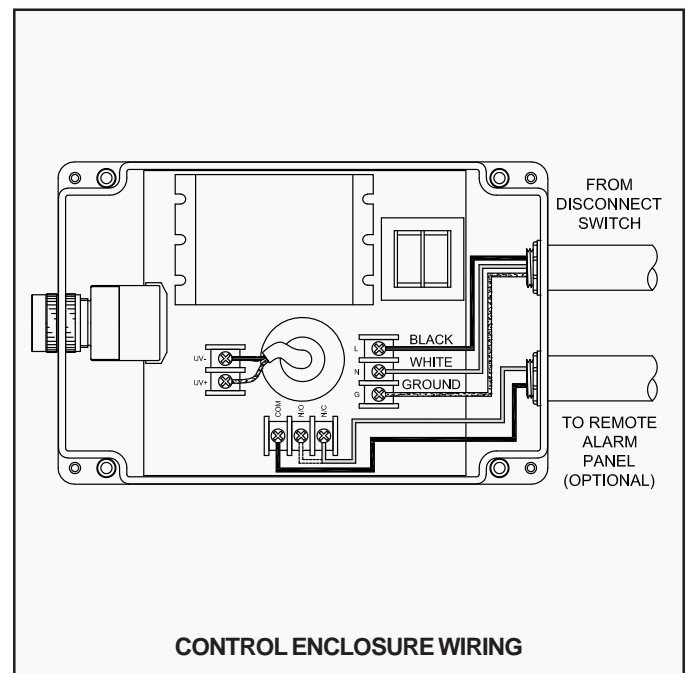

27. Install the interlock bracket onto the threaded cap and secure with the two screws provided.
28. Backfill around the disinfection chamber and riser pipe. Finished grade should be below the control enclosure mounting bracket to prevent the entry of surface water.
29. Turn "on" the UV breaker in the main electrical panel.
30. Turn "on" the power at the disconnect switch.
31. The green lamp on the control enclosure should now be illuminated to indicate the system is operational.

ULTRAVIOLET DISINFECTION (Cont.)

MAINTENANCE AND SERVICE

UV blocking protective eyewear must be worn during service or any time the bulb may be illuminated. It is recommended that the subassembly be removed and serviced every six months to insure proper disinfection. Inspect the Teflon sheath for damage or biological film. If the sheath is torn or biological film is present between the sheath and the quartz sleeve, the Teflon sheath must be replaced. Contact Norweco for replacement parts. If biological film is present on the surface of the Teflon sheath, the sheath must be cleaned to insure proper disinfection. To clean the Teflon sheath:

1. Insure power is turned off at the disconnect switch or in the main service panel.
2. Use a soft damp cloth to carefully wipe down the sheath.
3. Use isopropyl alcohol on a soft cloth to carefully remove difficult stains like fingerprints or biological film.

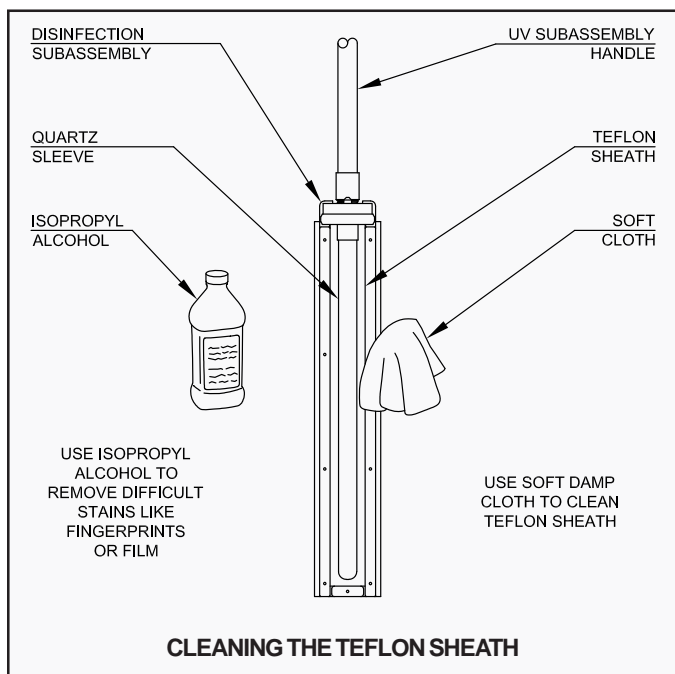

The system is designed to provide long service life. It is recommended that the UV lamp be replaced every two years to insure proper disinfection of the treatment system effluent. The green light on the side of the control enclosure will no longer illuminate when the lamp needs replaced. UV blocking protective eyewear must be worn during service or any time the bulb may be illuminated. To replace the lamp:

1. Turn off power to the UV system at the disconnect switch or in the main service panel. Confirm that the green indicator light on the side of the enclosure is "off".
2. Remove the interlock bracket and threaded cap.
3. Remove the subassembly from the disinfection chamber and disassemble the union in the handle. Use the power cable to remove the UV lamp from the subassembly.
4. Disconnect the UV lamp from the four pin connector on the power cable.
5. Use an entire tube of dielectric grease to thoroughly

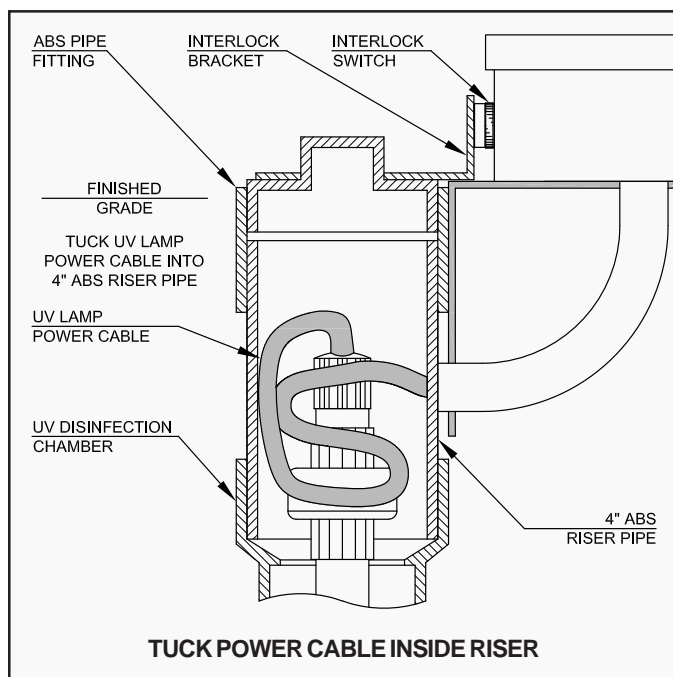

- coat the four pin connector and rubber sleeve. Connect new lamp and carefully lower into the UV subassembly. Make sure the lamp is fully seated in the quartz sleeve.
6. Reassemble and tighten the union in the handle.
 7. Lower the subassembly into the disinfection chamber.
 8. Reinstall the threaded cap onto the riser.
 9. Reinstall the interlock bracket onto the threaded cap and secure with the two screws provided.
 10. Turn on power at the disconnect switch or main service panel. Verify that the green indicator light on the side of the control enclosure is illuminated.

NOTE: The UV lamp contains mercury which is harmful to the environment. Insure that old UV lamps are disposed of at a recycling center.

ALARM CIRCUIT

The Model AT 1500 system is equipped with a current sensing circuit to monitor the UV lamp performance. If the UV lamp output drops below an acceptable level for proper disinfection, the alarm circuit will turn "off" the green indicator light on the enclosure. When connected to the Service Pro control center, the service provider can be immediately notified that maintenance to the UV system is required. For more information regarding connection of the Model AT 1500 UV disinfection system alarm to a Service Pro control center, please refer to the Service Pro Control Center with MCD Technology Installation and Operation Instructions.

MANUFACTURED BY

norweco
Engineering the future of water and wastewater treatment

NORWECO, INC.
NORWALK, OHIO
U.S.A. 44857
www.norweco.com