

NORWECO'S NEW WASTEWATER TREATMENT PLANT... THE SINGULAIR® CHEMICAL NPDES SYSTEM

REDUCTION IN BOD₅ / TSS THAT EXCEEDS 98% WITH
CHEMICAL DISINFECTION, DECHLORINATION AND POST AERATION

PERFORMANCE THAT PROTECTS THE ENVIRONMENT!

The Singulair® Chemical NPDES system has been approved for EPA General NPDES Permit applications and is perfect for sites where effluent disposal options are limited.

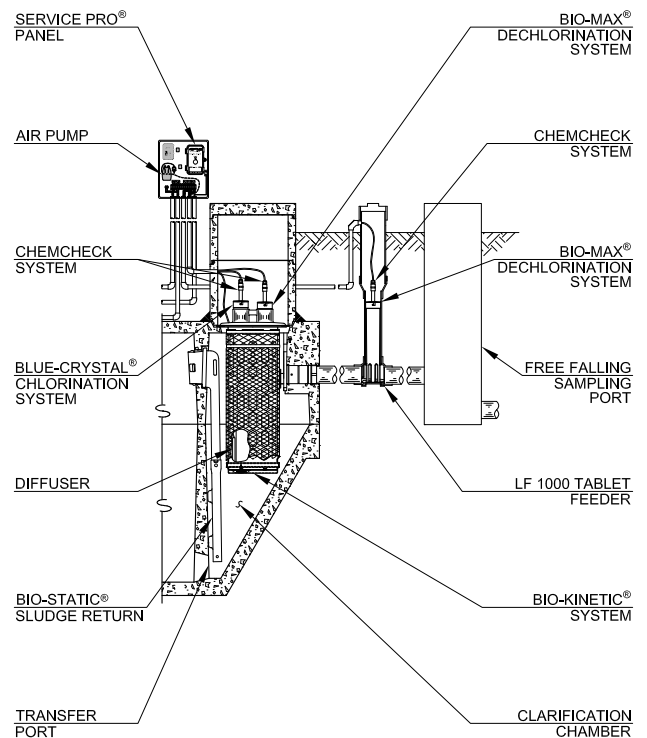
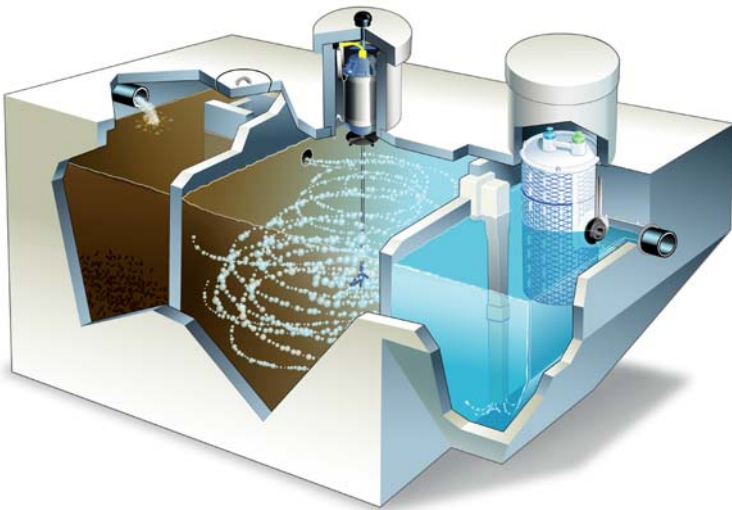

Seamlessly integrating several proven technologies, the Singulair® Chemical NPDES system's primary treatment platform is the Model TNT equipped with Service Pro® remote monitoring. The UL Listed Service Pro® control center automatically notifies service providers if a component alarm is detected.

Also included in this NPDES system is a chemical disinfection device, dechlorination devices, ChemCheck systems and post aeration. All components in the NEMA 4X rated equipment enclosure are pre-wired for ease of installation.



SINGULAIR® NPDES FEATURES

- Precast concrete tank
- Low maintenance
- Flow equalization
- Post aeration
- Lowest electrical usage
- Built-in chemical disinfection
- Dechlorination
- Lifetime aerator warranty and exchange
- Sold and serviced by local distributors
- Made in the U.S.A.

norweco®

*Engineering the future of water
and wastewater treatment*

220 REPUBLIC STREET
NORWALK, OHIO, USA 44857-1156
TELEPHONE (419) 668-4471
FAX (419) 663-5440
www.norweco.com