

norweco®

BIO-DYNAMIC®

FOR MODEL LF 1000, MODEL LF 2000, MODEL LF 3000

INSTALLATION AND OPERATION MANUAL

INTRODUCTION

Bio-Dynamic LF Series tablet feeders are complete dry chemical dosing systems for water, wastewater, stormwater and process water treatment. They are designed to provide automatic control over the chemical application rate and maximize installation flexibility. The LF Series tablet feeders consists of five separate models to accommodate flows ranging from less than 100 GPD through 400,000 GPD and chemical dosage ranging from 1 to 50 mg/L, depending upon the general component configuration, daily flow rate and the type of chemical tablets applied. All models of LF Series tablet feeders are manufactured from durable ABS and can be glued to Schedule 40 PVC piping. When properly installed, the Bio-Dynamic tablet feeders will provide long term, unattended operation and precise chemical application throughout their rated flow ranges. Please familiarize yourself with the contents of this manual before proceeding with installation and operation.

SYSTEM APPLICATION

Bio-Dynamic LF Series tablet feeders are designed to feed 2 5/8" diameter chemical tablets in gravity flow applications. These tablet feeders are not to be used for pressurized applications and must have a gravity outflow. Common applications for the LF Series tablet feeders are treating flows from septic tanks; aerobic treatment units; sand filters; rock reed filters; curtain drains; constructed wetlands; marine sanitation devices (MSD); individual, community and municipal drinking water systems; process water systems; reservoirs; water towers; cooling towers and irrigation systems. All LF Series tablet feeders can be installed at grade, in-line or below grade.

HOW THE LF SERIES TABLET FEEDERS WORK

Bio-Dynamic LF Series tablet feeders are flow rated proportional chemical dosing units. Flow to be treated enters the tablet feeders through the 4" integral inlet hub. The liquid then proceeds to the flow deck where the chemical tablets are contained in one to three chemical feed tubes. The number of chemical feed tubes varies by model. The flow deck has three levels (tiers) which accommodate varying hydraulic loads and properly channels liquid to the chemical tablets. Active chemicals are released into the flow stream as the liquid erodes the tablets. When the incoming flow rate increases, the liquid level in the tablet feeder rises. The increase in liquid level causes the flow to contact more tablets, thereby providing the additional chemical release required for consistent treatment. As the flow decreases, it contacts fewer tablets, reducing the chemical dosage. After contact with the chemical tablets, properly treated liquid exits the tablet feeder through the 4" outlet hub.

SYSTEM PERFORMANCE

Bio-Dynamic LF Series tablet feeders are listed as a chlorine dispenser for secondary effluent from residential wastewater treatment systems under NSF/ANSI Standard 46. Certification requires the use of Norweco Blue Crystal or Bio-Sanitizer disinfecting tablets and a chlorine contact tank of at least 11 1/2 gallons. Contact tank retention time must comply with the controlling regulatory jurisdiction. USEPA guidelines state "On the average, satisfactory disinfection of secondary wastewater effluent can be obtained when the chlorine residual is 0.5 ppm after 15 minutes contact." Significantly greater contact time can decrease disinfection efficiency and allow bacteria regrowth.

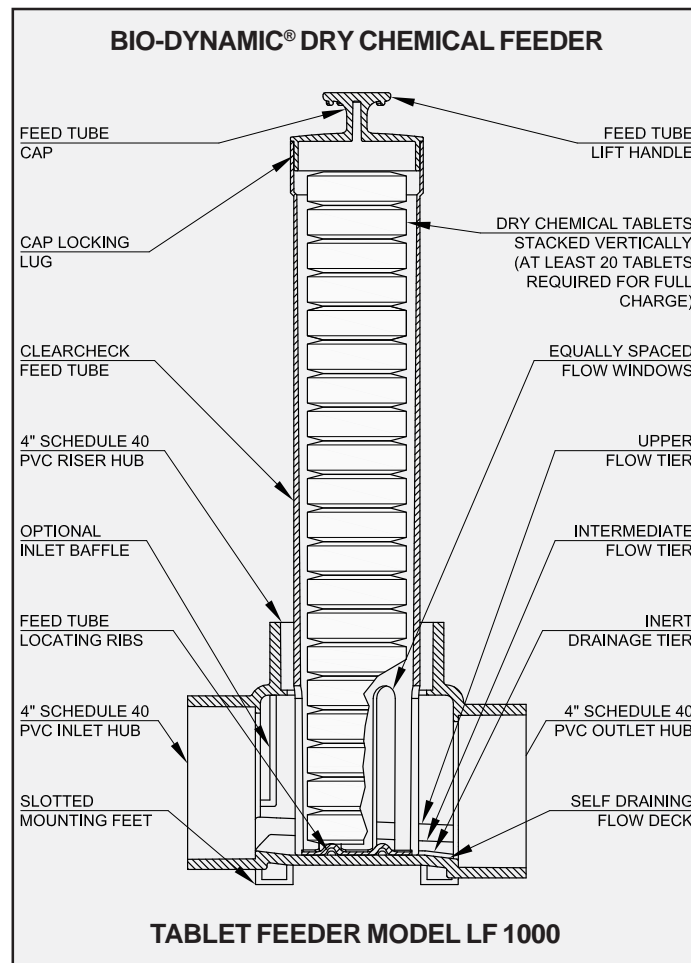

GENERAL INSTALLATION INSTRUCTIONS

Bio-Dynamic LF Series tablet feeders can be installed into any gravity flow water supply or wastewater treatment system. When used for potable water disinfection, the feeder is typically installed at grade following final filtration and just prior to a storage or detention tank. For wastewater disinfection applications, the tablet feeder is installed following clarification and prior to or in a chlorine contact tank. Installation can be at grade or direct buried. For dechlorination, feeders can be installed in or immediately following the chlorine contact tank. When chlorinating and dechlorinating effluent, two separate Bio-Dynamic tablet feeders must be installed. Do not mix chlorination and dechlorination tablets within the same tablet feeder.

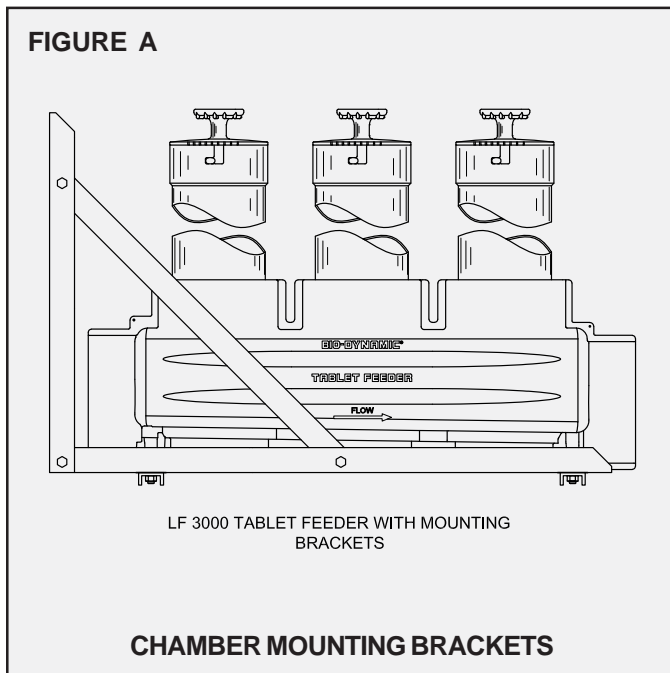

Integrally molded inlet and outlet hubs allow direct connection of the tablet feeder to Schedule 40 PVC piping. Adaptor couplings should be used, if necessary, to modify piping diameters and insure a secure piping connection to the tablet feeder. The effluent line must allow for a $\frac{1}{8}$ " fall per linear foot of run along the entire piping run. All tablet feeders must be installed plumb and level to insure proper operation. Place a bubble level on the feeder before final installation to confirm the unit is plumb and level, side to side and end to end. Always recheck level after installation.

INSTALLATION AT GRADE

LF Series tablet feeders can be installed at grade, in-line or mounted in the contact tank of a water or wastewater treatment system. The installation should be accessible for routine operator maintenance. To mount the unit, use $\frac{5}{16}$ " diameter corrosion resistant bolts to secure the four integrally molded mounting feet to the deck of the contact tank, concrete pad or mounting brackets, as required. For contact tank installations, use PVC or aluminum mounting brackets to prevent corrosion (See Figure A).

DIRECT BURIAL INSTALLATION

All models of LF Series tablet feeders may be installed below grade without a manhole or secondary enclosure. Prepare an excavation to the proper depth (See Figure B), including a sand or fine gravel leveling pad at least 4" thick. The tablet feeder must be supported by this pad before inlet and outlet piping is attached to the feeder. Excavated trenches should be smooth and free of debris to prevent damage to the pipe. Connecting lines should be laid continuously and unspliced to undisturbed earth beyond the limits of the excavation (See Figure C). Schedule 40 PVC, cast iron or similar materials may be used, subject to the approval of local codes. Attach the inlet and outlet lines to the inlet and outlet hubs using ABS compatible glue. A 4" Schedule 40 PVC pipe with tamper-proof cap (not supplied) will be used as a riser to grade. Connect the pipe to the riser hub using ABS compatible glue. Do not cement the cap. Check the system for plumb and level from side to side, end to end and vertically along the riser pipe. Backfill the excavation. Fine, loose fill should be used to backfill the excavation and plumbing line trenches. Exercise care when backfilling. Finished grade should be at least 6" below the top of the riser pipe and should slope away for surface drainage. Recheck that the feeder is plumb and level.

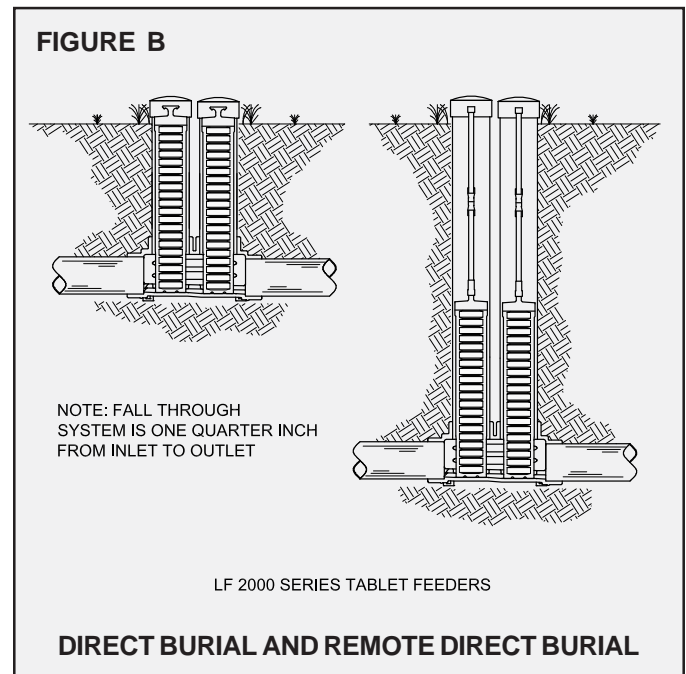

EXISTING SYSTEM RETROFIT

If the existing treatment system piping is in good condition, the feeder can be fitted directly into the appropriate location. When installing a tablet feeder into an existing disinfection system, it is recommended that the chlorine contact tank be pumped and thoroughly cleaned with a diluted bleach solution prior to installation of the feeder. Failure to properly clean the contact tank may result in inadequate disinfection of the wastewater. It is also necessary to inspect all upstream and downstream treatment components to confirm that they are installed and functioning properly.

TIERED FLOW DECK

A multi-tiered flow deck is incorporated in all LF Series tablet feeders. This allows consistent chemical application to low, sustained, variable, intermittent and surge flows. Liquid is channeled through the three tiers of the flow deck in proportion to the hydraulic load (See Figure D). The lowest tier of the flow deck is the inert drainage tier. The inert drainage tier directs liquid to the feed tube during low flow conditions and forms a drainage channel to dry the tablets when there is no flow. As the flow increases, the liquid is channeled through the intermediate flow tier. This tier directs the increased flow to the chemical tablets and allows more tablets to contact the liquid. At higher flow rates, the liquid rises to the upper flow tier. The upper tier dissipates excess flow velocity and produces a consistent chemical dosage. The flow deck incorporates a retaining ring with locating ribs for the feed tubes. The locating ribs engage positioning slots in the feed tube to secure the tube in the proper installation position for the feeder's rated capacity.

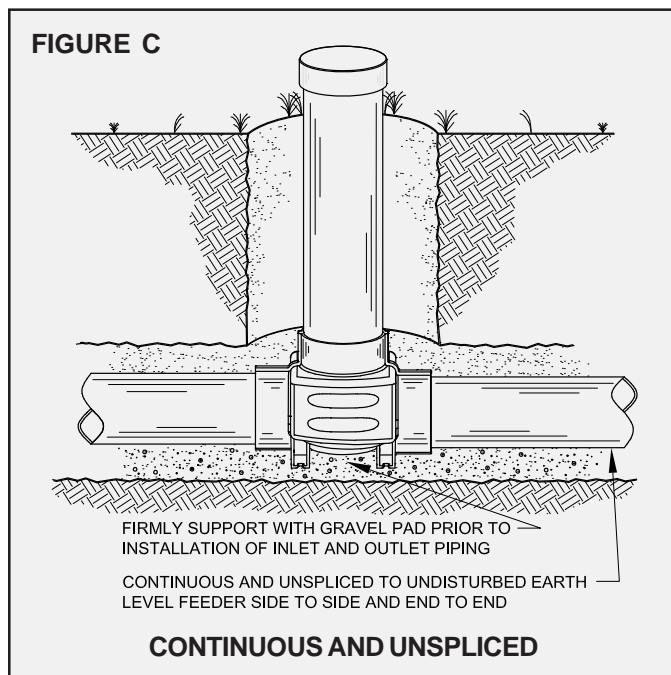

CLEARCHECK® FEED TUBE AND CAP

The LF Series tablet feeders are equipped with molded, chemical feed tubes with twist lock caps. Each feed tube and cap are constructed of NSF/ANSI Standard 61 listed PVC for durability and long life. The feed tube is manufactured with the translucent ClearCheck design. This design allows the operator or service provider to determine whether tablet refill is required simply by visual inspection without removing the tube from the feeder. The feed tube utilizes chemical tablets with the nominal weight and dimensions of 5 ounces, 2 ⁵/₈" diameter and ¹³/₁₆" to 1" height. Slots molded directly into the bottom of the feed tube allow the chemical tablets to dry during intermittent or prolonged no flow periods. The twist lock cap fits securely inside the chemical feed tube to allow convenient installation of the tube and cap within a 4" Schedule 40 PVC riser pipe.

REMOTE REMOVAL SYSTEM

A remote removal system is available for direct burial installations to allow for safe removal, recharge and reinstallation of the feed tube from grade. The remote removal system consists of a top-threaded feed tube cap, one extension and one handle. For use, replace the standard cap with the top-threaded cap. The top-threaded cap locks into the feed tube, then the extension and handle are threaded onto the top of the new cap (See Figure E). Additional extensions are available for deeper installations and can be added or removed any time. The extension(s) and handle remain in place during system operation and standard feed tube filling instructions apply.

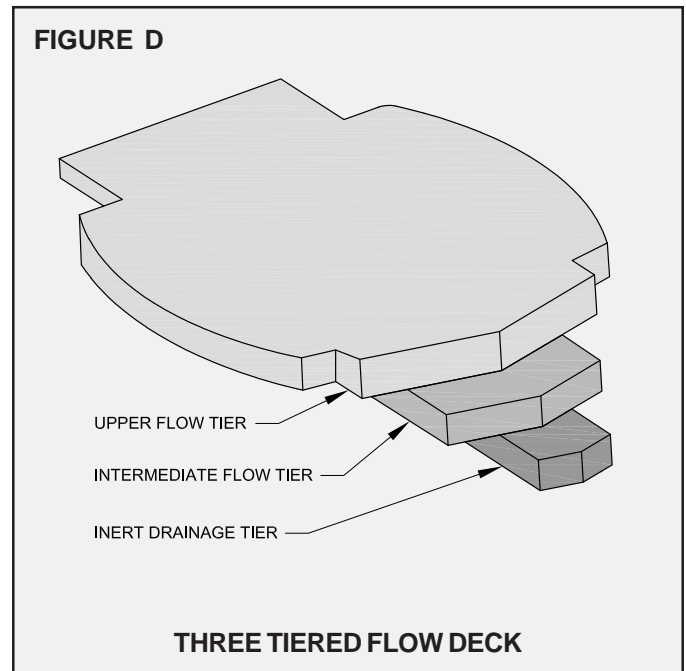

FILLING AND INSTALLING THE FEED TUBE

Before handling any chemical tablets, carefully read the product container label and the **CAUTION** section of these instructions. When filling the feed tube, always wear rubber gloves and safety goggles or a face shield for proper protection. Follow all handling instructions for the chemical tablets used. To fill the feed tube, remove it from the feeder. Rinse the feed tube and cap thoroughly with fresh water. Dry as required. Hold the tube, slotted end up, at a 30° to 45° angle and slide the chemical tablets into the open feed tube, one tablet at a time. Insure that each tablet lies flat, against the next and evenly on top of one another, in the feed tube (See Figure F). Use a gloved hand to retain the tablets inside the open end of the inverted tube until it has been evenly and completely filled. Carefully return the tube to the upright position. Replace the cap and slide the feed tube into the body of the feeder, slotted end down. The slots in the bottom of the feed tube must properly engage the locating ribs molded into the flow deck. Be sure the feed tube is fully engaged within the feeder and rests evenly on the flow deck. Utilize the Chemical Consumption Record on the back of this manual to track the chemical refill pattern.

BIO-SANITIZER® DISINFECTING TABLETS

If the tablet feeder is to be used for the disinfection of water or wastewater, a 10 lb., 25 lb., 45 lb. or 100 lb. supply of Bio-Sanitizer disinfecting tablets is available from your local distributor. Bio-Sanitizer tablets insure dependable disinfection for water and wastewater treatment system flow and other applications where a predictable long-term source of chlorine is desirable. The tablets are manufactured from pure calcium hypochlorite and contain at least 70% available chlorine. Bio-Sanitizer disinfecting tablets are registered with the USEPA for water and wastewater treatment. The tablets incorporate beveled edges to enhance the chemical dissolution pattern, providing effective and economical bacteria killing power. Each tablet is $2\frac{5}{8}$ " diameter, compressed to a $\frac{13}{16}$ " thickness, has an approximate weight of 5 ounces and is white in color for easy identification. The chemical application rate of Bio-Sanitizer tablets remains consistent at peak flow factors as high as four.

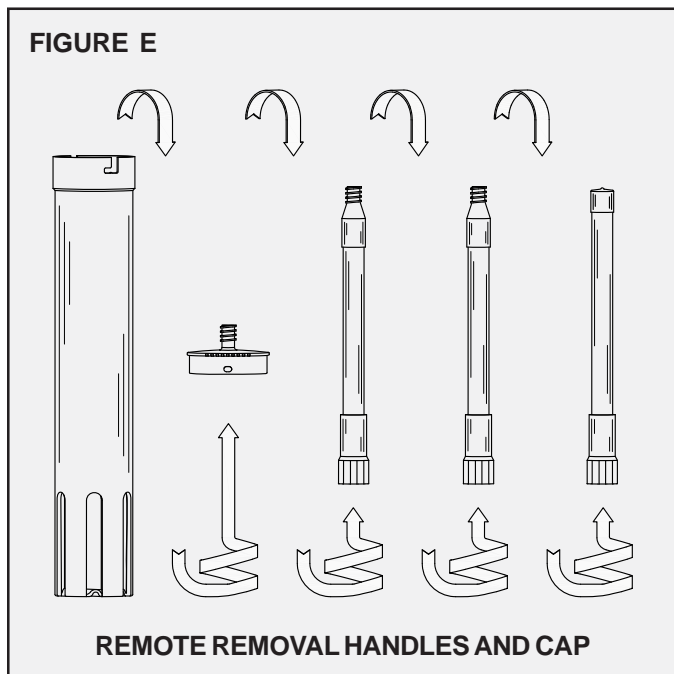

BLUE CRYSTAL® DISINFECTING TABLETS

If the tablet feeder is to be used for the disinfection of residential wastewater, a 1.9 lb., 10 lb. or 100 lb. supply of Blue Crystal residential disinfecting tablets is available from your local distributor. Blue Crystal tablets are the first disinfectant that has been specifically developed for use in residential wastewater treatment applications. Formulated to maintain positive disinfection during the low, sustained, variable and intermittent flow rates that are common to residential wastewater treatment systems, Blue Crystal tablets are produced with a proprietary beveled edge design to enhance the chemical dissolution pattern. Each tablet is $2\frac{5}{8}$ " diameter, compressed to a 1" thickness, has an approximate weight of 5 ounces and is white in color with blue crystals for easy identification. Containing a minimum of 70% available chlorine, Blue Crystal tablets are registered with the USEPA for wastewater treatment.

BIO-MAX® DECHLORINATION TABLETS

If the tablet feeder is to be used for the dechlorination of water or wastewater, 10 lb. and 48 lb. supply of Bio-Max dechlorination tablets is available from your local distributor. Containing 92% sodium sulfite, the tablets are manufactured to neutralize both free and combined chlorine. Bio-Max tablets incorporate beveled edges to enhance the chemical dissolution pattern. Each tablet is $2\frac{5}{8}$ " diameter, compressed to a $\frac{13}{16}$ " thickness, weighs approximately 5 ounces and is green in color for easy identification. The tablets dissolve slowly, releasing controlled amounts of chemical for the instantaneous removal of residual chlorine from the water or wastewater flow. The chemical application rate of the tablets remains consistent at peak flow factors as high as four. Bio-Max tablets are formulated to remove chlorine residuals to non-detectable levels.

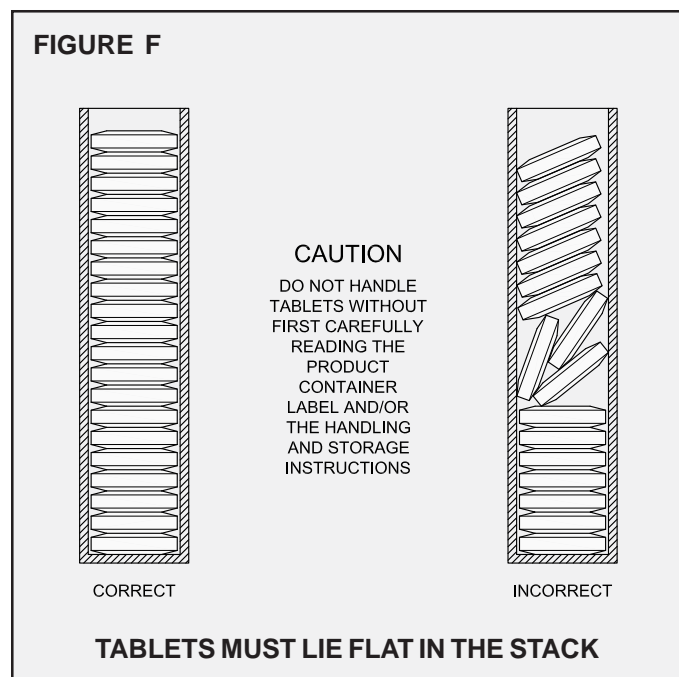

BIO-PERC® REMEDIATION TABLETS

If the tablet feeder is to be used for the bioaugmentation of wastewater, a 10 lb. supply of Bio-Perc biological remediation tablets is available from your local distributor. Bio-Perc tablets rejuvenate failing wastewater treatment systems by reducing or eliminating organic buildup in distribution lines and disposal processes. Bio-Perc tablets help sand filters and soil-based treatment systems recover their infiltrative capacity while preventing the failure of new installations. Each tablet is $2\frac{5}{8}$ " diameter, compressed to a 1" thickness, has an approximate weight of 5 ounces and incorporates a beveled edge design to reduce wicking.

CAUTION: All chemicals and chemical feed systems should be handled with care. Chemicals and feed tubes should not be mixed with each other or any other products. Do not handle tablets or feed tubes without first carefully reading the product container label, MSDS information and the handling and storage instructions.

PLACING THE BIO-DYNAMIC® ON-LINE

Be sure the entire liquid stream from the facility being served flows through the tablet feeder. Confirm that the proper chemical tablets are being used in the feed tube and that the feed tube is firmly engaged into the retaining ring and locating ribs of the flow deck. After the system has been in operation for at least one hour, draw a sample of the treated effluent from the feeder outlet or the contact chamber inlet to test the chemical application. For chlorination applications, testing can be done using a chlorine test kit, available from your Bio-Dynamic distributor, or a DPD Colorimetric test as outlined in the most recent edition of Standard Methods for the Examination of Water and Wastewater. Dechlorination applications may also require that a chlorine residual test be performed. Multiple samples must be taken to insure that the system has reached equilibrium. Take samples at 15 minute intervals. When three or more consecutive samples produce the same results, the system has reached equilibrium. In direct burial installations, make sure the riser pipe extends at least 6" above grade and is covered securely by a tamper-proof pipe cap.

OPERATIONAL ADJUSTMENT

LF Series feeders can be adjusted without taking the unit off-line. When fully inserted into the feeder body, the feed tube locks into locating ribs molded into the flow deck. This locked position provides the maximum chemical dose. Rotating the feed tube clockwise, one-quarter ($1/4$) turn from its fully locked position raises the feed tube approximately one-eighth inch ($1/8$ "). By raising the feed tube, the chemical delivery can be reduced. Please refer to the Operational Adjustment Chart at the bottom of this page for routine guidance. If there are additional questions regarding operation, contact your local Bio-Dynamic distributor. For further reference, a red identification tag with the contact information of the manufacturer is attached to the feeder.

ROUTINE MAINTENANCE

LF Series feeders require very little maintenance other than periodic cleaning and refilling of the feed tubes. When performing maintenance, always wear rubber gloves and safety goggles or a face shield and follow the procedures outlined in the handling instructions for the chemicals used in the feeder. Before refilling the feed tubes, rinse the tube and cap thoroughly with fresh water. Occasionally, a feed tube may need to be cleaned with a brush. A service brush for cleaning the feed tube and flow deck is available from your local Bio-Dynamic distributor. To use the brush, remove the extension handle from the top-threaded feed tube cap and screw the brush into the handle. When refilling the feed tube, check the inside of the feeder and rinse any residue with a low pressure hose. Dry the feed tube with a clean cloth before reinserting chemical tablets. The liquid flow will normally prevent accumulation of debris during routine operation. Debris that may become lodged within the feeder during a malfunction of the upstream treatment system can be removed with the cleaning brush or a gloved hand.

INTERMITTENT USAGE

During a period of intermittent use or extended period of non-use, feed tubes should be removed and stored in a well-ventilated, dry, secure location. Refer to the tablet container label and material safety data sheet for detailed safety, storage and/or disposal instructions for the chemical tablets. Reinstall the riser cap securely for the time period the system will be unattended.

OPERATIONAL ADJUSTMENT CHART		
Condition	Possible Cause	Recommended Remedy
Insufficient Chemical Application	Feed tube empty	Refill chemical tablets
	Incorrect type of tablets used	Replace using properly approved tablets
	Feed tube not properly installed	Install the feed tube flat on flow deck
	Tablets jammed in the feed tube	Remove, clean and properly refill the feed tube
	Excess solids in effluent	Troubleshoot treatment plant
	Debris clogging bottom of the feed tube	Remove, clean and properly refill the feed tube
	Tablet feeder not level	Adjust mounting position
	Tablets more than one year old	Remove, clean and properly refill the feed tube
Overapplication of Chemical	Incorrect type of tablets used	Replace using properly approved tablets
	Blockage at outlet	Rinse feeder with fresh water to remove blockage
	Too many tablets immersed	Rotate the feed tube clockwise 90 degrees
	Excess hydraulic flow	Equalize flow prior to the tablet feeder
	Recirculation piping not properly adjusted	Increase percentage of recirculation flow
	Tablet feeder not level	Adjust mounting position

