

## NORWALK PRECAST MOLDS' COMMITMENT TO QUALITY

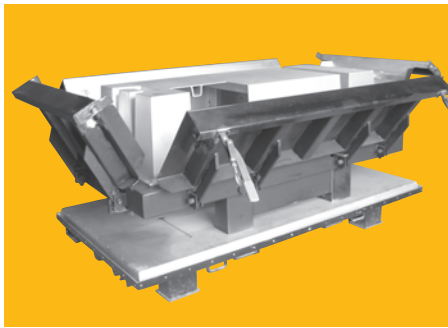

The Norwalk Precast Molds' commitment to quality means two things to our customers. First, since 1906, we have taken pride in satisfying our customers by delivering precast molds and services that meet their specified requirements at the agreed price and schedule. Second, we are committed to continuously improve the processes by which we provide our molds

and services so that your finished precast concrete products meet requirements and are molded perfectly the first time.

### FACILITIES AND SKILLS

We maintain an active, company-wide quality program that demands the integrity of each employee and that places responsibility for quality with the people here who do the work. We continuously improve our fabrication facilities and replenish our inventories to make sure we always meet our commitments to you. We recognize that customer appraisal of our performance is critical to our reputation, and we know that your satisfaction is the key to our success. Please let us know what you think of our performance and tell us how we can serve you better. Just visit our website at [www.norwalkprecastmolds.com](http://www.norwalkprecastmolds.com) and fill out our customer feedback form.



# NORWALK PRECAST MOLDS' COMMITMENT TO QUALITY

Member:  
American Cemetery  
Association  
Association of  
Iowa Cemeteries

## HARLINGTON MUNICIPAL CEMETERY

CITY OF WAVERLY

GEO. E. LANE, Cemetery Superintendent

Waverly, Iowa

May 25, 1959

The Norwalk Vault Co.  
Norwalk, Ohio  
Mr. A. M. Lendrum, Pres.

Dear Mr. Lendrum:-

The recent photograph which I sent you was buried in Harlington Cemetery January 24, 1916. This was a Lane-Norwalk vault as manufactured by my father, the late C. E. Lane. This vault and body was removed from original grave to another spot on the lot April 10, 1959. The vault was in excellent condition, tests were made and there was no indication of water on the inside. This vault contained the remains of Helen Paukner, 12 years of age. During the past several years we have disinterred several Lane-Norwalk vaults, which have always been found in perfect condition but this particular vault had been buried for the longest period of time and thought you might like the photo of same.

You are well

above information in any way

Sincerely,

*Geo. E. Lane*



OUR  
COMMITMENT TO  
QUALITY HAS BEEN  
EVIDENT FROM  
THE START.