

norweco[®]

HYDRA-MAX[®]

DECHLORINATION SYSTEM

INSTALLATION AND OPERATION MANUAL

INTRODUCTION

The Hydra-Max dechlorination system is designed to provide automatic dosing of dechlorination tablets to remove chlorine residual from pressurized water flows. Constructed of 6061-T6 high strength, aircraft grade aluminum for maximum strength and durability, the Hydra-Max system requires no electro-mechanical components. It can accommodate flows from 150 to 900 gallons per minute (GPM). The compact size and built-in handle on the system provide easy transportation between jobsites. The device comes equipped with a 2 ½" NST coupling at the inlet and a flow directional swivel elbow on the outlet. This unique feature allows the direction of the outflow to be locked into place. When properly installed and operated, the Hydra-Max system will provide complete removal of free and combined chlorine. Please familiarize yourself with the contents of this manual before proceeding with installation and operation.

SYSTEM APPLICATION

The Hydra-Max dechlorination system is designed to accept 2 5/8" diameter Enviro-C or Bio-Max dechlorination tablets. The most common application for the Hydra-Max system is dechlorination of water flows during fire hydrant flushing. The system can also be utilized for flushing new water mains or backflushing swimming pools. A stainless steel tablet cartridge contains multiple ¼" flow ports to provide the proper amount of mixing and contact with tablets. This allows for complete neutralization of chlorine and chloramines while keeping chemical waste to a minimum. The Hydra-Max system provides a fast and simple set-up that saves operators time and money. There are no mechanical parts that require adjustment or components that can be easily damaged or broken. The compact, durable one piece construction offers operators a low cost, low maintenance system.

HOW THE HYDRA-MAX[®] SYSTEM WORKS

The Hydra-Max system is a flow rated device designed to safely apply chemicals in pressurized applications to remove residual chlorine. The Hydra-Max dechlorination system provides consistent and precise neutralization of chlorine to meet stringent water treatment requirements mandated by Federal, State and Local regulations. The Hydra-Max system can be used for treating water flows discharging from fire hydrants, swimming pools and new water mains. When backflushing swimming pools or flushing new water mains, the Hydra-Max system is typically installed at the discharge point of the water flow and connected to a hose specified for these applications. The Hydra-Max system incorporates a 2 ½" NST coupling for easy and fast connection to any fire hydrant. The outlet incorporates 2 ½" NST male threads for use with hoses, pilot gauges or other test equipment. During operation, flow enters through the inlet hub and is channeled through the compact dosing chamber. As flow passes through the system, it dissolves the dechlorination tablets to provide complete removal of free and combined chlorine from

the flow. It is recommended that you check the removable tablet cartridge after 15 minutes of operation. If needed, add tablets and continue flushing.

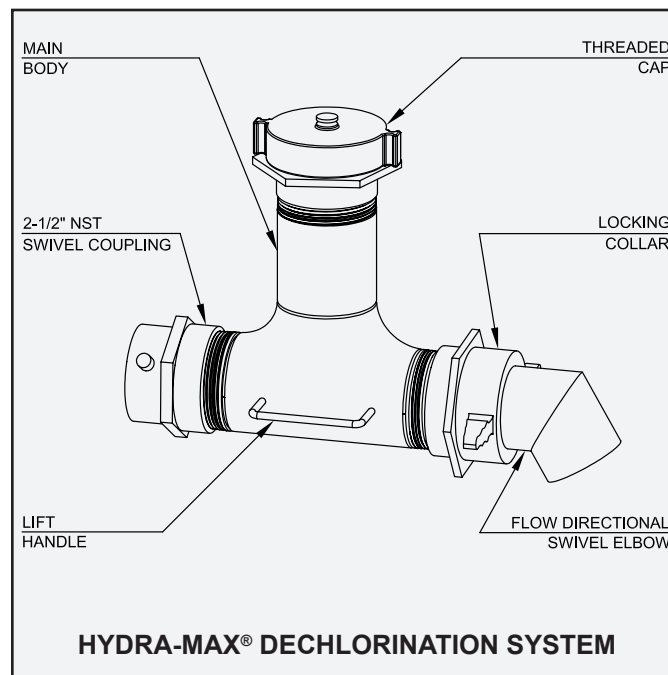

the flow. It is recommended that you check the removable tablet cartridge after 15 minutes of operation. If needed, add tablets and continue flushing.

SYSTEM PERFORMANCE

The Hydra-Max dechlorination system has been designed for a flush rate of 150 to 900 GPM with chlorine levels up to 4 ppm. The complete set-up time is 1-3 minutes and typically requires only one operator. The Hydra-Max system provides a fast and easy way to dechlorinate pressurized flows in the most cost effective and efficient manner when utilizing Norweco's Enviro-C or Bio-Max dechlorination tablets.

HYDRA-MAX® INSTALLATION AND OPERATION MANUAL

GENERAL INSTALLATION INSTRUCTIONS

The Hydra-Max dechlorination system is most commonly utilized for fire hydrant flushing. Follow the instructions below for fast and easy installation to any fire hydrant. Norweco's Enviro-C dechlorination tablets, manufactured from pure Vitamin C, are the recommended tablets for this application to obtain the most effective treatment.

1. Secure the Hydra-Max system to the fire hydrant utilizing the 2 ½" NST coupling.
2. Position the outlet flow directional swivel elbow to desired location. Secure with the locking collar.
3. Remove threaded cap and tablet cartridge. Fill cartridge with eight Enviro-C tablets.
4. Replace tablet cartridge into the main body, pushing the cartridge to the bottom of the chamber.
5. Reinstall the threaded cap. Hand tighten only.
6. Initiate flushing and refill tablets as necessary.

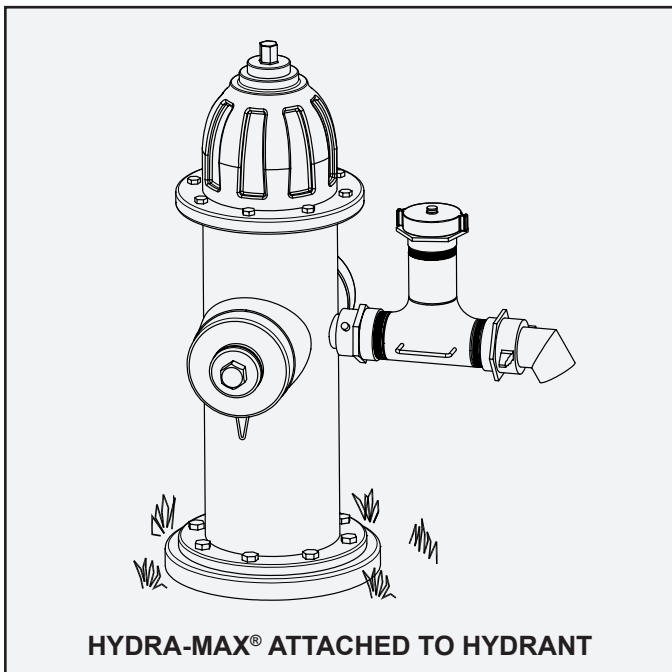

ROUTINE MAINTENANCE

The Hydra-Max system requires little maintenance other than periodic cleaning and refill of the stainless steel tablet cartridge. When performing any maintenance, always wear proper gloves and safety goggles or a face shield. Follow the procedures outlined in the handling instructions for the chemicals being used with the system. Before refilling the tablet cartridge, check the inside of the tube and rinse any residue with a low pressure hose. Occasionally, the tablet cartridge may need to be cleaned with a brush. The liquid flow will normally prevent accumulation of sediment or debris during routine operation. Lodged sediment or debris within the system can be removed with the cleaning brush or a gloved hand. If the use of a brush is required, reference the Cleaning Brush section for detailed instructions.

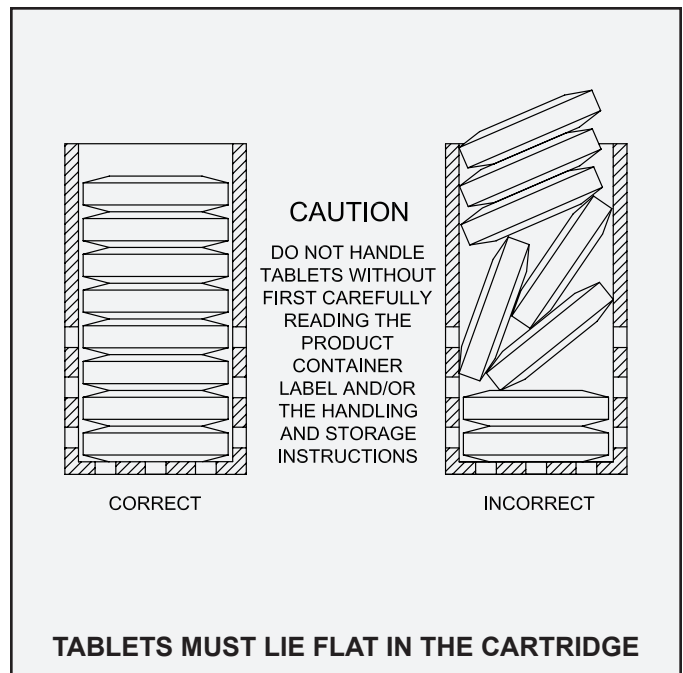

FILLING AND INSTALLING TABLETS

Before handling any chemical tablets, carefully read the product container label and the **CAUTION** section of these instructions. When filling the removable stainless steel tablet cartridge, always wear gloves and safety goggles or a face shield for proper protection. Follow all handling instructions for the chemical tablets being used. To fill the tablet cartridge, remove it from the main body. Rinse the cartridge tube thoroughly with fresh water. Dry as required. Hold the cartridge at a 30° to 45° angle and slide the chemical tablets into the open end of the cartridge, one tablet at a time. Insure that each tablet lies flat against the next and evenly on top of one another. Carefully return the tablet cartridge to the main body. Be sure the cartridge is fully engaged into the system. Replace the threaded cap to secure the tablet cartridge in place. Utilize the Chemical Consumption Record on the back of this manual to track the chemical refill pattern.

CLEANING BRUSH

A brush for cleaning the removable tablet cartridge and main body is available from your local Hydra-Max system distributor. The cleaning brush can also be used to clean the inlet and outlet hubs of the system if necessary. To use the cleaning brush, wet the brush with fresh water and hold the cartridge over a clear area. Gently swab the cartridge to remove any buildup of tablet residue. Lower brush into the main body to clean the dosing chamber and inside of the system. If required, the brush can also be used to clean the inside of the flow directional swivel elbow. Thoroughly rinse the brush and the system with fresh water to finish the cleaning process. Dry as needed. Store the brush in an area away from debris for future use.

HYDRA-MAX® INSTALLATION AND OPERATION MANUAL

ENVIRO-C® DECHLORINATION TABLETS

If the Hydra-Max system is to be used for the dechlorination of water or wastewater, a (5 lb., 10 lb., or 35 lb.) supply of Enviro-C dechlorination tablets is available from your local distributor. Enviro-C dechlorination tablets use the unique chemistry of Vitamin C to neutralize chlorine and chloramines from water, wastewater and process water applications. Containing 75% ascorbic acid, Enviro-C tablets assist in meeting stringent discharge limitations in a fast and effective manner. Each tablet is 2 5/8" diameter, compressed to a 1" thickness, weighs approximately 4 ounces and is orange in color for easy identification. Enviro-C tablets incorporate a beveled edge to enhance the chemical dissolution pattern. The Enviro-C tablets provide a consistent reduction or elimination of chlorine residual without significantly reducing dissolved oxygen. This tablet can be used in all major gravity and pressure rated tablet feeders or other devices such as diffuser equipment. Enviro-C tablets are non-toxic to fish and other aquatic life. When dosed correctly, it will take 1 gram of ascorbic acid to neutralize 1 mg/L of chlorine per 100 gallons of water.

TRI-MAX® TABLET FEEDER

The Tri-Max tablet feeder is a dry chemical dosing system for water, wastewater or process water treatment. It provides operators a way to use chemical tablets without installing traditional feeders to existing plant piping or assembling liquid chemical dosing systems in the field. The Tri-Max system is constructed of heavy duty stainless steel for maximum strength and durability. It is designed to accept 2 5/8" diameter chemical tablets and is equipped with three feed tubes. The Tri-Max tablet feeder may be installed at grade, in-line, mounted in the contact tank or below grade within a manhole or secondary enclosure. The system contains handles on the outer two feed tube housings to assist with installation of the tablet feeder and transportation between jobsites. When utilizing the Tri-Max tablet feeder for disinfection, contact time is required after the flow passes through the system.

BIO-DYNAMIC® TABLET FEEDERS

Bio-Dynamic tablet feeders are self-contained dry chemical dosing systems for the treatment of water, wastewater or process water. A low cost, low maintenance and effective method of chemical treatment, Bio-Dynamic feeders have no mechanical components and require no electricity. With fifteen different models, Bio-Dynamic feeders have multiple installation options that provide maximum flexibility and accommodate flows ranging from less than 100 GPD through 400,000 GPD. All Bio-Dynamic tablet feeders have a built-in tiered flow deck that allows for consistent chemical application during low, sustained, variable, intermittent and surge flows. Additional chemical dosage control options are available in many models.

BIO-MAX® DECHLORINATION TABLETS

If the Hydra-Max system is to be used for the dechlorination of water or wastewater, a 48 lb. supply of Bio-Max tablets is available from your local distributor. Containing 92% sodium sulfite, the tablets are manufactured to neutralize both free and combined chlorine. Bio-Max tablets incorporate beveled edges to enhance the chemical dissolution pattern. Each tablet is 2 5/8" diameter, compressed to a 1 1/16" thickness, weighs approximately 5 ounces and is green in color for easy identification. The tablets dissolve slowly, releasing controlled amounts of chemical for the instantaneous removal of residual chlorine from the water or wastewater flow. Bio-Max tablets assist plant operators in meeting stringent chlorine discharge limitations in a low cost, low maintenance, environmentally safe manner. This tablet can be used in all major gravity or pressure rated tablet feeders and other devices such as diffuser equipment. The chemical application rate of the tablets remains consistent at peak flow factors as high as four. Bio-Max tablets are formulated to remove chlorine residuals to non-detectable levels.

CAUTION: The improper handling or use of Enviro-C or Bio-Max tablets may cause personal injury or property damage. All chemicals, chemical feed systems and components should be handled with care. Keep out of the reach of children and do not allow the tablets or feed tubes to contact skin, eyes or clothing. Tablets may be fatal if swallowed and tablet dust is irritating to the eyes, nose and throat. Do not handle the tablets or feed tubes without carefully reading the product container label, safety data sheet (SDS) and the safety, handling and storage instructions. For additional information about these products, contact your local distributor.



BIO-DYNAMIC® TABLET FEEDERS

